



540 HP

SITRAK C7H

ERGONOMIC DESIGN

- Driver and Passenger ISRI seats
- Dual Continental displays
- ADR approved double bunk
- Sleeper cab air conditioner

BUILT FOR POWER

- 540 HP German Technology Engine
- 12 Speed ZF Traxon transmission
- ZF Intarder 3
- 90 Tonne rated

SAFETY AT ITS FINEST

- Adaptive cruise control
- Advanced emergency braking
- Hill start assist
- Lane departure warning



SPECIFICATIONS C7H PRIME MOVER

DIMENSIONS (mm)

		Low Roof (SWB)	High-Roof (LWB)
OAL	Overall length	7100	7108
FOH	Front overhang	1475	1475
WB	Wheelbase	3900	4100
	Axle Spread	1400	1400
RO	Rear overhang	1725	1533
FSC		805	1090
RT	Rear Track	1816	1816
ORT	Outer Rear Track	2500	2500
	Front ground clearance	270	270
	Rear ground clearance	200	200
	Turning circle (kerb to kerb)	15010	15580
	Turning circle (wall to wall)	16790	17380
	Approach Angle (°)	15	15
	Departure Angle (°)	46	46

CAB DIMENSIONS (mm)

		Low Roof (SWB)	High-Roof (LWB)
OH	Unladen height	3595	4040
	Laden height	3524	4015
CW	Cab width	2490	2496

SUSPENSION (mm)

		Low Roof (SWB)	High-Roof (LWB)
RFH	Unladen	1010	983
	Laden	980	953

MASS RATINGS

- GVM / GCM 25.0 tonnes / 90.0 tonnes

	Low Roof (SWB)	High-Roof (LWB)
Chassis mass front	5.08 tonnes*	5.40 tonnes*
Chassis mass rear	3.59 tonnes*	3.54 tonnes*
Chassis mass total	8.67 tonnes*	8.94 tonnes*

*Weights are to standard configuration and include chassis cab with no driver or fuel

ENGINE

540 hp Euro 5 German Technology MCI 3.54-50

Power Rating: 397 kw @ 1900 rpm

Maximum Torque: 2500 Nm @ 1050-1350 rpm

Emissions Technology: Selective Catalytic Reduction

Total Displacement: 12.419 litre

Exhaust: Catalytic muffler with integrated SCR catalyser

TRANSMISSION

12-speed ZF TraXon AMT

Model: ZF12TX2621TD

- 2-pedal operation with automatic or manual shift control

Standard: Retarder (ZF Intarder 3)

STEERING

Type: ZF 8098 power-assisted with gear driven pump

Gear Ratio: 23:01 (22.20-26.20)

FRONT AXLE & SUSPENSION

Type: HF7 (Disc)

Capacity: 7.0 tonnes

Suspension Type: Non-Independent 3 parabolic leaf springs

REAR AXLE & SUSPENSION

Sinotruk MCY13 (Disc)

Capacity: 18.0 tonnes

Ratios: 3.08

- Optional: 2.85, 3.70, 4.11

Suspension Type: Air Ride 8 Bags with ECAS to control ride height

Differential: Driver controlled inter-axle lock and differential lock

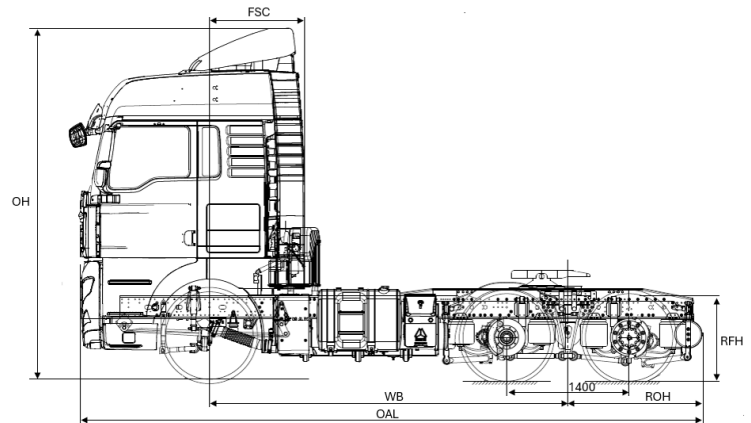

BRAKES

Type: Wabco EBS/ESC/ASR

Park Brake: Spring brake

Auxiliary Braking: 2 Stage air-controlled exhaust brake and 5 stage retarder

Front Diameter: 430 mm Disc

Rear Diameter: 375 mm Disc

- Aluminium air reservoirs

FUEL CAPACITY

Low Roof: 600 litre rectangular aluminium tank & 90 litre AdBlue tank (RHS) and 370 litre rectangular aluminium tank (RHS)

High-Roof: 800 litre rectangular aluminium tank & 90 litre AdBlue tank (LHS) and 370 litre rectangular aluminium tank (RHS)

CHASSIS

Type: 270 x 85 x 8 mm medium tensile steel channel

- Polypropylene bumper with fog and driving lights

- FUPS

- Trapezium Frame

ELECTRICAL SYSTEM

Type: Double/Control Positive Pole

Voltage: 24 Volt

Batteries: 2x12V 180 Ah with isolation switch

Alternator: 28 Volt – 110 Amp

WHEELS & TYRES

Wheels: 22.5x9.0 10-stud 335 mm alloy

Front Tyres: 295/80 R22.5

Rear Tyres: 11 R22.5

CAB FEATURES

- Fully adjustable ISRI self-levelling air suspension driver's and passenger seat with headrest, armrest, heated and ventilated, adjustable damper and integrated lap-sash retractor seat belt
- Lane Departure Warning (LDW)
- Automatic Emergency Braking (AEB)
- Active Cruise Control (ACC)
- 90° opening doors with electronically operated windows
- LCD Multimedia touchscreen Radio/Wi-Fi/Bluetooth and steering wheel controls
- Overhead storage compartments, centre console drawer and tray, dual cupholders, door pockets, passenger dash tray
- Automatic climate control
- Daytime Running Lights (DRL)
- Electrohydraulic cab tilt
- Four-point cab mounting system with air bag suspension
- Double Bunk (High-Roof)
- Sleeper cab cooler
- Heated and electric exterior mirrors with independent convex "spotter" mirror
- CCTV 4 camera front, rear and side facing
- Under bunk dual zone fridge and freezer