

# Specifications

T5G 8x4 Cab Chassis



## LK AUTO PTY LTD

A. 8 Progress Cct,  
Prestons NSW 2170  
P. 02 8119 7609  
E. [info@lkauto.com.au](mailto:info@lkauto.com.au)  
W. [lkauto.com.au](http://lkauto.com.au)

## Features

- 330hp German Technology Euro V Engine
- 6 Speed Allison Automatic Gearbox
- Driver and Passenger ISRI Heated and Ventilated Seats
- Adaptive Cruise Control and Lane Departure Warning
- Wabco Systems
- Henrickson Air Suspension

# SITRAK

## SPECIFICATIONS T5G 8x4



### DIMENSIONS (mm)

		8x4 SWB (Agitator Spec)	8x4 LWB (Cargo Spec)
OAL	Overall length	8230	11530
FOH	Front overhang	1430	1430
	Steer spread	1800	1800
WB	Wheelbase	5100	6800
	Axle Spread	1400	1400
ROH	Rear overhang	1700	3300
FSC		460	471
CT		4640	6329
CBL		6430	9629
RT	Rear Track	1827	1835
ORT	Outer Rear Track	2459	2469
	Front ground clearance	285	285
	Rear ground clearance	250	250
	Turning circle (kerb to kerb)	14820	16700
	Approach Angle (°)	19	19
	Departure Angle (°)	18	18

### CAB DIMENSIONS (mm)

		8x4 SWB (Agitator Spec)	8x4 LWB (Cargo Spec)
OH	Unladen height	3075	3080
	Laden height	3015	3020
CW	Cab width	2488	2487

### SUSPENSION (mm)

		8x4 SWB (Agitator Spec)	8x4 LWB (Cargo Spec)
FFA	Unladen	1060	1060
	Laden	1085	1070
RFH	Unladen	1100	1070
	Laden	1040	1010

### MASS RATINGS

- GML / GCM 27.5 tonnes / 50.0 tonnes

	8x4 SWB (Agitator Spec)	8x4 LWB (Cargo Spec)
Chassis mass front	5.34 tonnes*	5.68 tonnes*
Chassis mass rear	2.70 tonnes*	3.27 tonnes*
Chassis mass total	8.04 tonnes*	8.95 tonnes*

\*Weights are to standard configuration and include chassis cab with no driver or fuel.

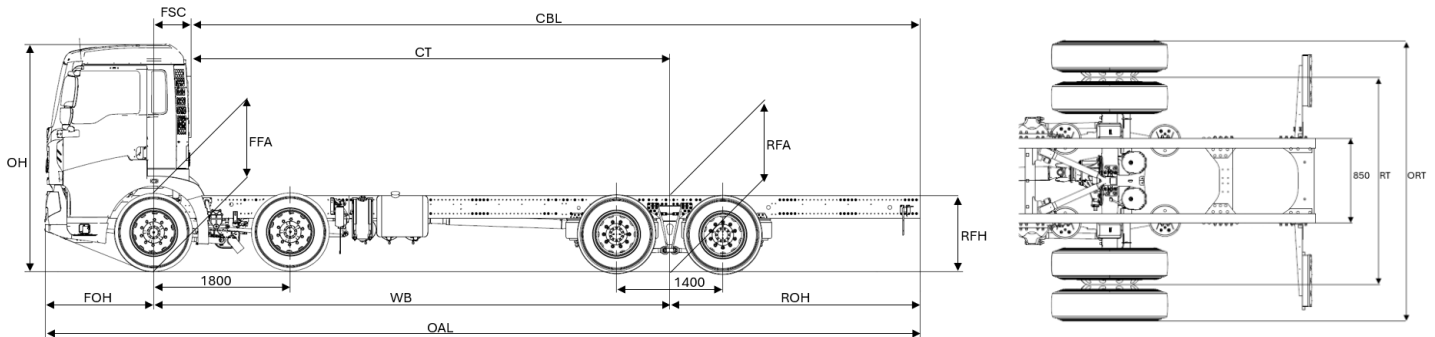

### ENGINE

330 hp German Technology MC07.33-50

**Power Rating:** 240 kw @ 2300 rpm

**Maximum Torque:** 1250 Nm @ 1200-1800 rpm

**Emissions Technology:** Selective Catalytic Reduction

**Total Displacement:** 6.870 litre

**Exhaust:** Catalytic muffler with integrated SCR catalyser

### TRANSMISSION

6-speed Allison Automatic

**Model:** 3200P Series

- 2-pedal operation with automatic and manual shift control

**Optional:** Power Take-Off (PTO) (Standard on SWB)

### STEERING

**Type:** ZF 8098 power-assisted with gear driven pump

**Gear Ratio:** 23:01 (22.20~26.20)

### FRONT AXLE & SUSPENSION

**Type:** VPD060QB (Disc)

**Capacity:** 7.0/7.0 tonnes

**Suspension Type:** Non-Independent 3 parabolic leaf springs

### REAR AXLE & SUSPENSION

Sinotruk MCY11 (Disc)

**Capacity:** 13.0/13.0 tonnes

**Ratios:** 5.29

- Optional: 3.08, 3.36, 3.7, 4.11, 4.63

**Suspension Type:** Hendrickson 4 bag (SWB) and 8 bag (LWB) with ECAS to control ride height

**Differential:** Driver controlled differential locks

### BRAKES

**Type:** Wabco EBS/ESC (SWB) EBS/ESC/EBL/ASR (LWB)

**Park Brake:** Spring brake acting on axle 2,3,4 (SWB) Spring stored energy air cut brake (LWB) (Maxi)

**Auxiliary Braking:** Air controlled exhaust brake

**Front Diameter:** 430 mm Disc

**Rear Diameter:** 375 mm Disc

- Aluminium air reservoirs

### FUEL CAPACITY

**8x4 SWB:** 200 litre rectangular aluminium tank & 40 litre AdBlue tank (LHS)

**8x4 LWB:** 600 litre rectangular aluminium tank & 40 litre AdBlue tank (LHS)

### CHASSIS

**Type:** 300 x 80 x 8 mm steel channel

- Polypropylene bumper with fog and driving lights
- FUP
- Trapezium Frame

### ELECTRICAL SYSTEM

**Type:** Double/Control Positive Pole

**Voltage:** 24 Volt

**Batteries:** 2x12V 180 Ah with isolation switch

**Alternator:** 28 Volt – 80 Amp 2.2 kw (SWB) 2.0 kw (LWB)

### WHEELS & TYRES

**Wheels:** 22.5x9.0 10-stud 335 mm alloy

**Front Tyres:** 295/80 R22.5

**Rear Tyres:** 11 R22.5

### CAB FEATURES

- Fully adjustable ISRI self-levelling air suspension driver's and passenger seat with headrest, armrest, heated and ventilated, adjustable damper and integrated lap-sash retractor seat belt
- Lane Departure Warning (LDW) (SWL)
- Automatic Emergency Braking (AEB) (SWL)
- Active Cruise Control (ACC) (SWL)
- 90° opening doors with electronically operated windows
- 7.1" Multimedia touchscreen Radio/Wi-Fi/Bluetooth and steering wheel controls
- Overhead storage compartments, centre console drawer and tray, dual cupholders, door pockets.
- Automatic climate control
- Daytime Running Lights (DRL)
- Electro Hydraulic cab tilt
- Four-point cab mounting system with mechanical suspension and dampers at rear
- Heated and electric exterior mirrors with independent convex "spotter" mirror
- CCTV 4 camera front, rear and side facing
- Centre console fridge/freezer (SWB)