

Specifications

G7 6x4 Tipper Cab Chassis

G7 8x4 Tipper Cab Chassis



**6x4 configuration shown*

LK AUTO PTY LTD

A. 8 Progress Cct,
Prestons NSW 2170
P. 02 8119 7609
E. info@lkauto.com.au
W. lkauto.com.au

Features

- 540hp MAN Technology Euro V Engine
- 12 Speed ZF TraXon AMT Gearbox
- Driver and Passenger ISRI Heated and Ventilated Seats
- Sleeper Cab Air Conditioner
- Wabco Systems
- Hendrickson Air Suspension

SITRAK

SPECIFICATIONS G7 540hp

DIMENSIONS (mm)

		6x4	8x4
OAL	Overall length	7975	9725
FOH	Front overhang	1475	1475
	Steer spread	N/A	1950
WB	Wheelbase	4300	6050
	Axle Spread	1400	1400
RO	Rear overhang	2200	2200
FSC		805	808
CT		3495	5242
CBL		5695	7442
RT	Rear Track	1817	1850
ORT	Outer Rear Track	2450	2480
CD	Chassis Rail Distance	762	766
	Front ground clearance	285	285
	Rear ground clearance	215	215
	Turning circle (kerb to kerb)	14130	20470
	Approach Angle (°)	15	15
	Departure Angle (°)	46	20

CAB DIMENSIONS (mm)

		6x4	8x4
OH	Unladen height	3205	3272
	Laden height	3145	3212
CW	Cab width	2492	2492

SUSPENSION (mm)

		6x4	8x4
FFA	Unladen	1045	1055
	Laden	1035	1010
RFH	Unladen	991	991
	Laden	971	971

MASS RATINGS

- GVM / GCM 25.0 tonnes / 75.0 tonnes (6x4)
- GVM / GCM 32.0 tonnes / 75.0 tonnes (8x4)

	6x4	8x4
Chassis mass front	4.85 tonnes*	6.15 tonnes*
Chassis mass rear	3.57 tonnes*	3.02 tonnes*
Chassis mass total	8.42 tonnes*	9.17 tonnes*

*Weights are to standard configuration and include chassis cab with no driver or fuel.

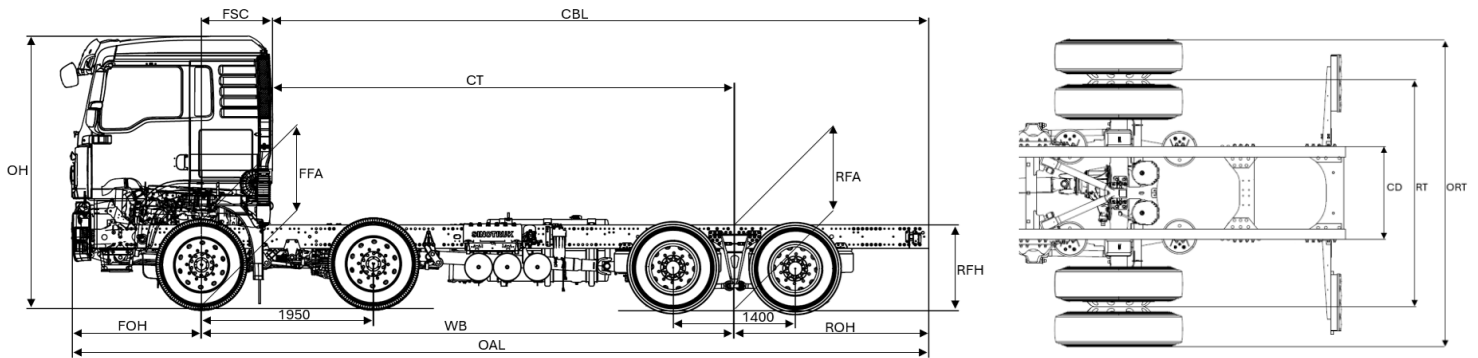

*Second steer axle non-existent on 6x4.

ENGINE

540 hp MAN Technology MC13.540-50

Power Rating: 397 kw @ 1900 rpm

Maximum Torque: 2500 Nm @ 1050-1350 rpm

Emissions Technology: Selective Catalytic Reduction

Total Displacement: 12.419 litre

Exhaust: Catalytic muffler with integrated SCR catalyser

TRANSMISSION

12-speed ZF TraXon AMT

Model: ZF12TX2621TD

- 2-pedal operation with automatic or manual shift control

Standard: Retarder and ZF Power Take-Off (PTO)

STEERING

Type: ZF 8098 power-assisted with gear driven pump

Gear Ratio: 23:01 (22.20~26.20)

FRONT AXLE & SUSPENSION

Type: HF7 (Disc)

Capacity: 7.0 tonnes (6x4) 14.0 tonnes (8x4)

Suspension Type: Non-Independent 3 parabolic leaf springs

REAR AXLE & SUSPENSION

Sinotruk MCY13 (Disc)

Capacity: 18.0 tonnes

Ratios: 3.08

- Optional: 2.85, 3.7, 4.11

Suspension Type: Hendrickson 8 bag with ECAS to control ride height

Differential: Driver controlled differential locks

BRAKES

Type: Wabco EBS/ESC/EBL/ASR

Park Brake: Spring stored energy air cut brake

Auxiliary Braking: Air controlled exhaust brake and Retarder

Front Diameter: 375 mm Disc

Rear Diameter: 430 mm Disc

- Aluminium air reservoirs

FUEL CAPACITY

6x4: 600 litre rectangular aluminium tank (RHS) & 40 litre AdBlue tank (LHS)

8x4: 600 litre rectangular aluminium tank & 40 litre AdBlue tank (LHS)

CHASSIS

Type: 270 x 85 x 8 mm medium tensile steel channel

- FUPS
- Trapezium Frame

ELECTRICAL SYSTEM

Type: Double/Control Positive Pole

Voltage: 24 Volt

Batteries: 2x12V 180 Ah with isolation switch

Alternator: 28 Volt – 80 Amp 2.0 kw

WHEELS & TYRES

Wheels: 22.5x9.0 10-stud 285 mm PCD steel

Front Tyres: 295/80 R22.5

Rear Tyres: 11 R22.5

CAB FEATURES

- Fully adjustable ISRI self-levelling air suspension driver's and passenger seat with headrest, armrest, heated and ventilated, adjustable damper and integrated lap-sash retractor seat belt
- 90° opening doors with electronically operated windows
- 7.1" Multimedia touchscreen Radio/Wi-Fi/Bluetooth and steering wheel controls
- Overhead storage compartments, centre console drawer and tray, dual cupholders, door pockets.
- Automatic climate control
- Daytime Running Lights (DRL)
- Hydraulic cab tilt
- Four-point cab mounting system with air bag suspension
- Heated and electric exterior mirrors with independent convex "spotter" mirror
- CCTV 4 camera front, rear and side facing
- Centre console fridge
- Sleeper cab cooler
- UHF CB Radio